

# Radial & Sirocco Fan

## 直翼式與多翼式風機 壓力扇



IE3  
Premium Efficiency

CHUAN FAN



台灣產品新型專利第 339596 • 345887 • 205327 • 142704 • 375137 • D145679 號  
中國產品新型專利第 1243826 號

## 用途

- 印刷機械
- 燃燒機
- 塑膠押出機、吹袋機淋膜機
- 製果機械
- 集塵機
- 環境機械
- 熱風發生機
- 粉粒體輸送
- 廚房機械
- 木工機械
- 乾燥機
- 焚化爐
- 恆溫箱
- 機械冷卻
- 一般送風



PF 直翼式



CS 多翼式



MS/FMS 多翼式

## 特點

- 大風量·低噪音·輕量化
- 採用鋁合金材質，大幅降低重量，達到輕量化的目的。
- 馬達為 I.E.C.設計 (1 HP以上)，全閉外扇型鋁框馬達，特殊軸心設計，可適合長時間使用。
- 特殊葉片設計，壓力高·風量大·噪音低·壽命長。
- 樣式種類齊全·庫存多·交貨迅速。

## Applications

- Printing Machines
- Burning Machines
- Plastic Extruders, Laminating, Film Making Machines
- Uniform Temperature Equipment
- Household Machines
- Dust Collectors
- Textile Machines
- Pollution Machines
- Hot Air Blowers
- Dryers Machines
- Incinerators
- Machinery for the Food and Beverage Industries
- Machinery for Cooling
- Woodworking Machines
- Grain elevators



低壓鑄造機

*Low Pressure Casting Machines*



重力壓鑄機

*Gravity Die Casting Machines*



壓鑄機

*Die Casting Machines*



CNC 加工區

*CNC Machining area*



IE3全自動馬達繞線/  
入線/整形機與生產線

*IE3 Automatic motor Stator winding/  
Wedge Inserter/ Coil Forming  
Machinery and Production Line*



馬達組裝與自動測試

*Motor Assembly & Test Line*

## Features

- Larger flow • Light in weight
- Aluminum alloy material was Widespread be use, offer light products.
- I. E. C. Designed motor Series above 1HP, Squirrel Cage Induction Motors & specially designated shaft can satisfy long-time-continue operation.
- Professional impeller designed, high pressure, larger flow • low noise • Long time use.
- Full range styles and sufficiently finished products of each model make quickly delivery be possible.

# 直翼式風機 Plate Fan (Radial Fan)

at 50/60Hz 2Pole

型式 Type	相數 Phase	功率 Output (kW)	電壓 Voltage (V)	電流 Current (A)	最大靜壓(吐出) Pressure (kPa)	最大風量(吐出) Air Flow (m <sup>3</sup> /min)	入/出口徑 In/Out Let (mm)	噪音 Noise Level (dB)	重量 Weight (kg)
PF75-02	1~ 3~	0.12	220 220/380	0.8 0.7/0.45	0.5/0.7	5/6	100/75	72/75	6
PF100-05N	1~ 3~	0.37	220 220/380	2.5 1.9/1.2	0.7/1	9.5/11	100/100	83/88	11
PF125-1	1~ 3~	0.74	220 220/380	5 3/1.8	0.7/1.2	14/17	125/125	85/90	17
PF150-2	3~	1.5	220 380	5.5 3.5	1.3/1.9	28/33	150/150	88/92	28
PF150-3	3~	2.2	220 380	8 5	1.4/2.3	30/35	150/150	89/93	34
PF200-5-X (60Hz 專用)	3~	3.7	220	13	2.6	70	200/200	99	47
PF200-5 (50Hz 專用)	3~	3.7	380	7.5	1.8	67	200/200	93	47
PF200-7.5 (60Hz 專用)	3~	5.5	220	19	2.8	78	200/200	99	59

PF型性能表 Characteristic curves

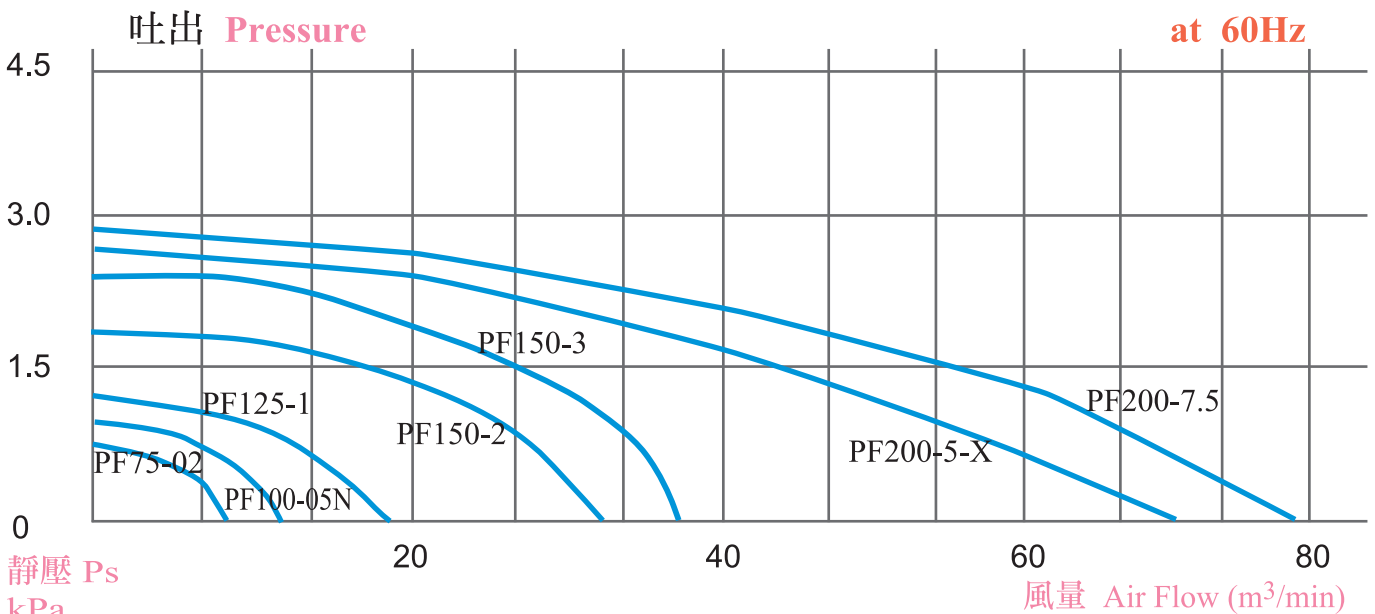
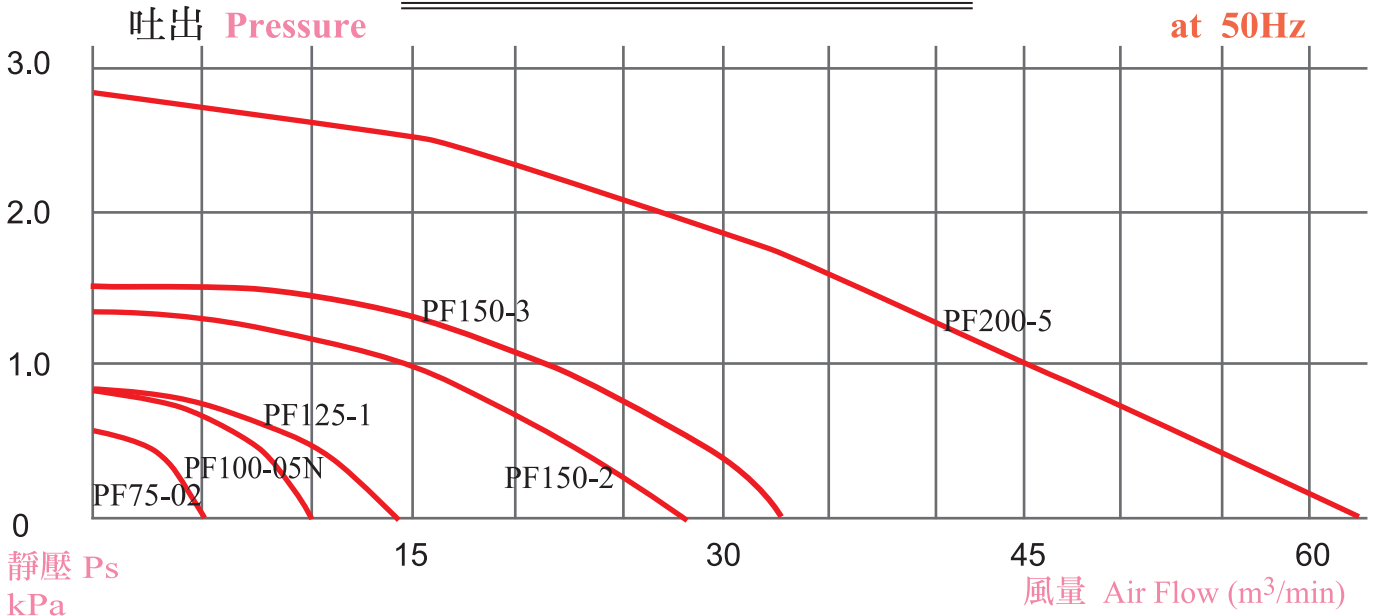

# 直翼式風機 Plate Fan (Radial Fan)

尺寸圖 Dimension (mm)

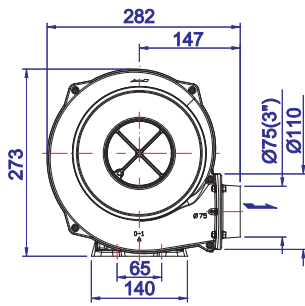

**PF75-02**

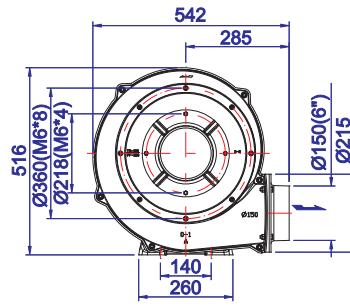
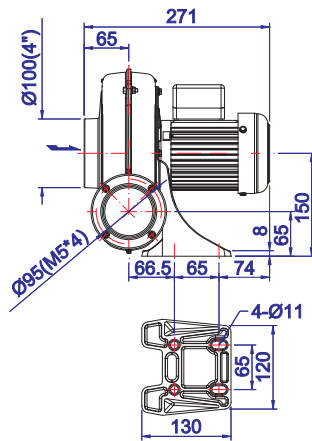

**PF150-2**

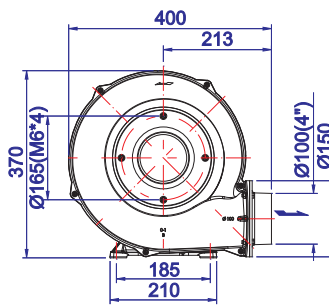
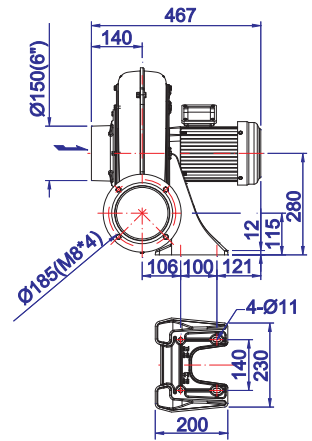

**PF100-05N**

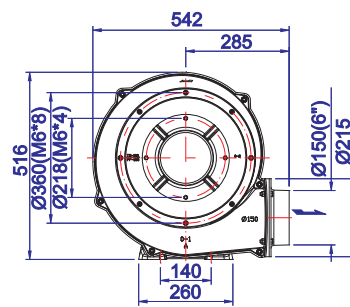
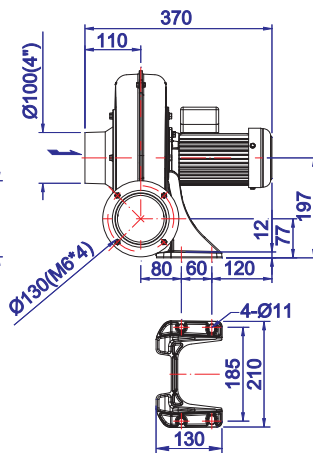

**PF150-3**

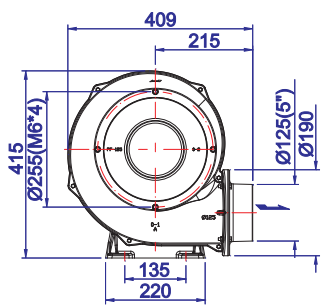
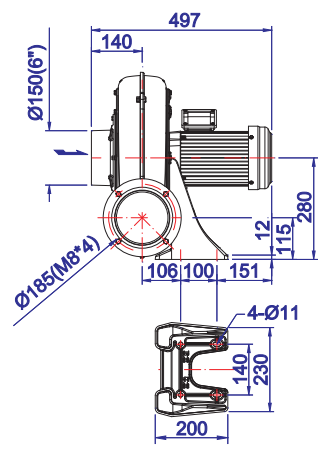

**PF125-1**

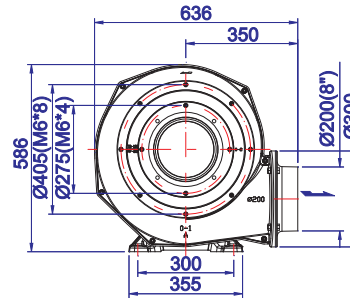
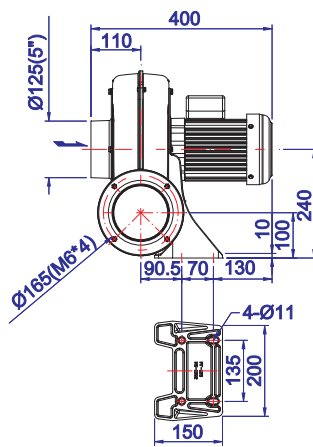

**PF200-5-(X)**

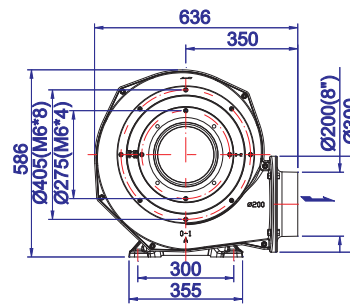
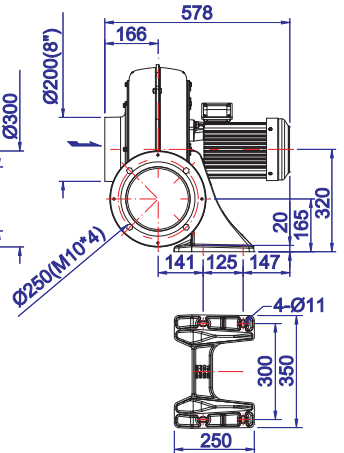

**PF200-7.5**

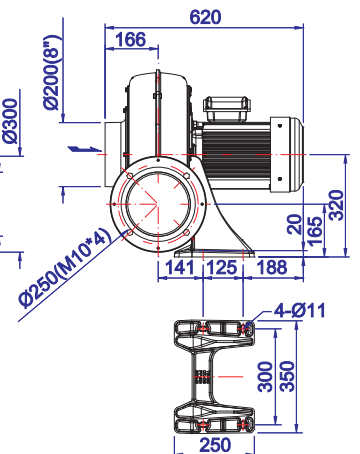

# 多翼式風機 Sirocco Fan (Centrifugal Fan)

at 50/60Hz 2Pole

型式 Type	相數 Phase	功率 Output (kW)	電壓 Voltage (V)	電流 Current (A)	最大靜壓(吐出) Pressure (kPa)	最大風量(吐出) Air Flow (m <sup>3</sup> /min)	出口口徑 In/Out Let (mm)	噪音 Noise Level (dB)	重量 Weight (kg)
CS-50	1~ 3~	0.074	220 220/380	0.6 0.5/0.3	0.3/0.5	3/3.5	50	55/60	3.5
CS75-02	1~ 3~	0.12	220 220/380	0.8 0.7/0.45	0.4/0.6	6/7	75	70/73	5
CS100-05N	1~ 3~	0.37	220 220/380	2.5 1.9/1.2	0.5/0.8	13/15	100	78/80	12
CS125-1	1~ 3~	0.74	220 220/380	5 3/1.8	0.6/0.9	17/20	125	79/82	17
CS150-2	3~	1.5	220 380	5.5 3.5	0.9/1.3	26/35	150	80/85	29
CS150-3	3~	2.2	220 380	8 5	1.1/1.7	35/45	150	81/86	33
CS200-5	3~	3.7	220 380	13 7.5	1.6/2.2	60/70	200	85/90	49

CS型性能表 Characteristic curves

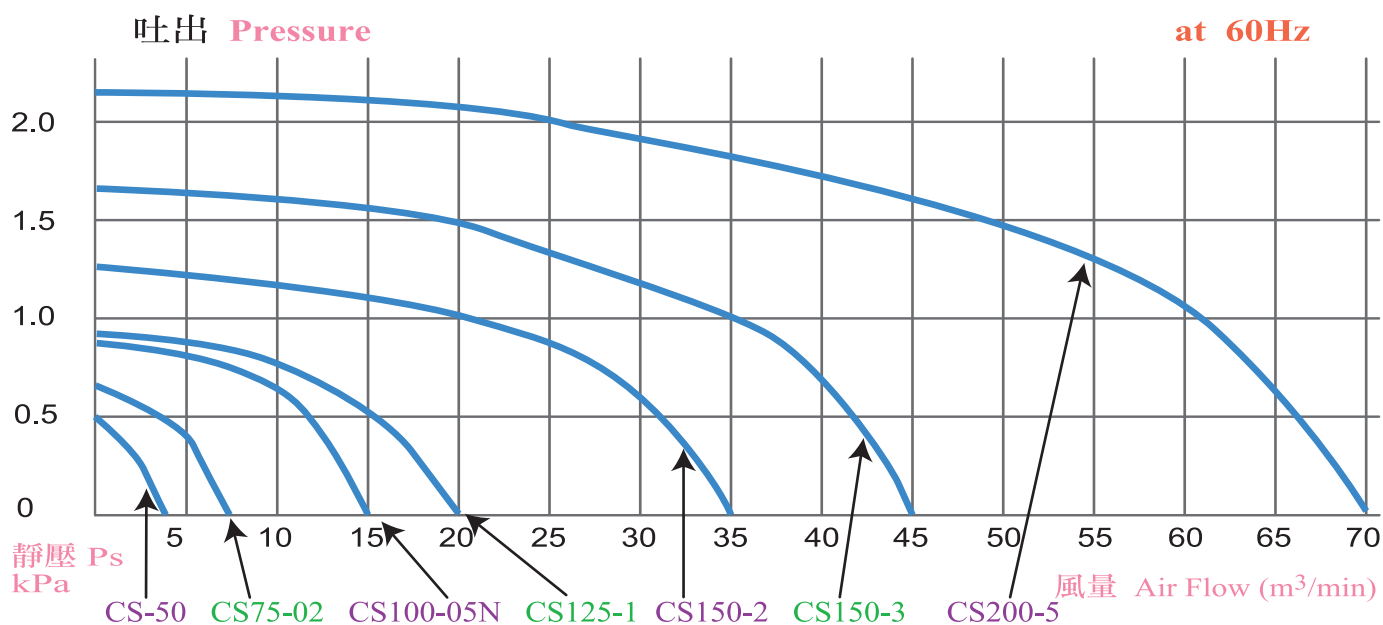
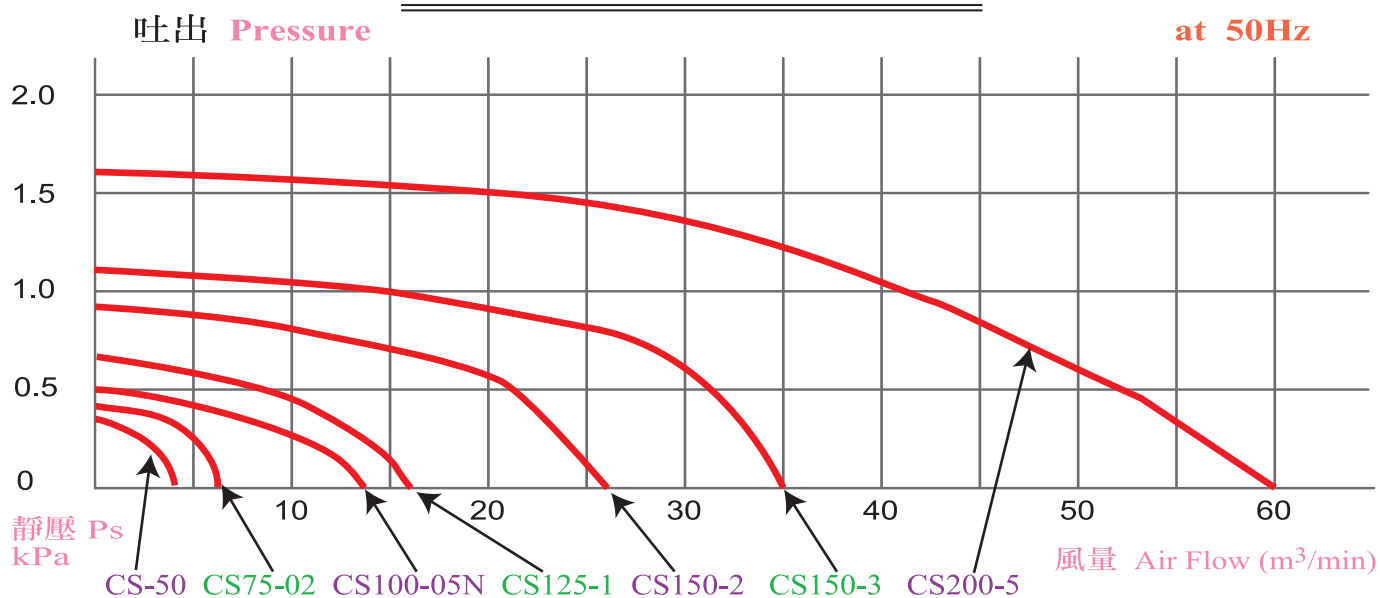

# 多翼式風機 Sirocco Fan (Centrifugal Fan)

尺寸圖 Dimension (mm)

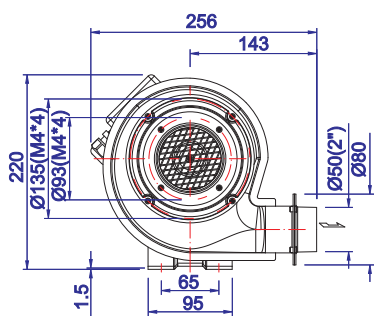

**CS-50**

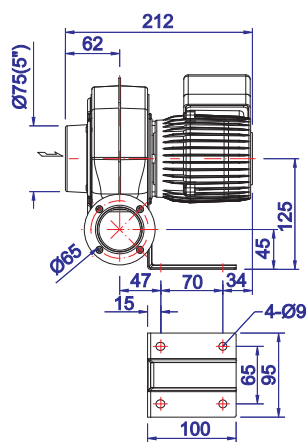

**CS125-1**

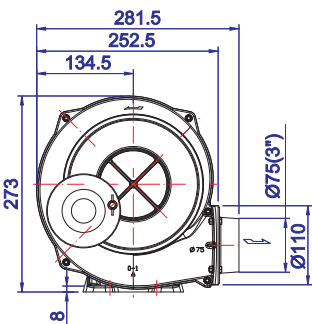
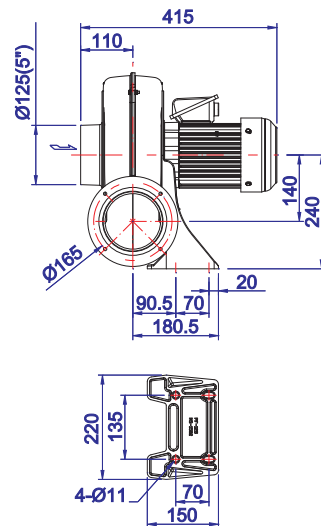

**CS75-02**

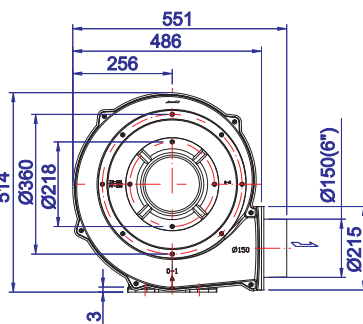
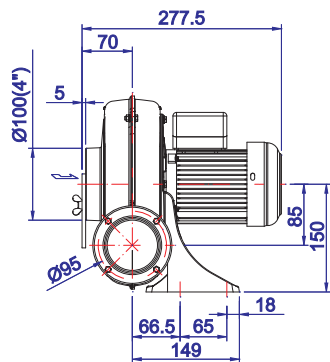

**CS150-2(CS150-3)**

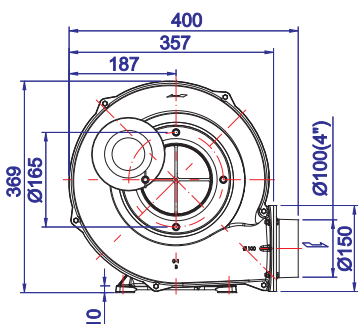
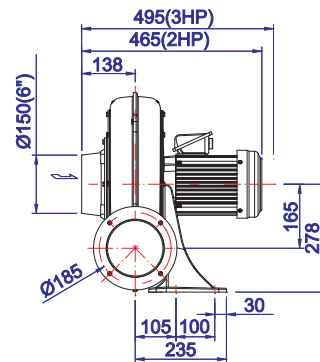

**CS100-05N**

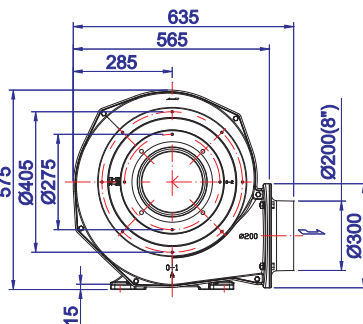
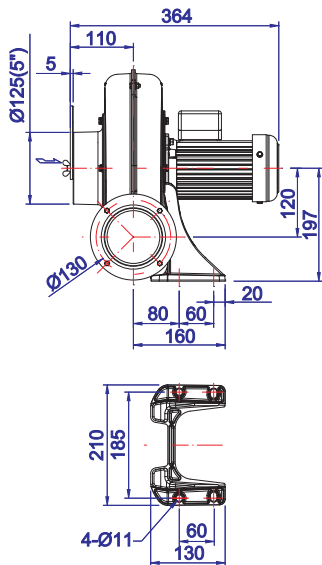

**CS200-5**

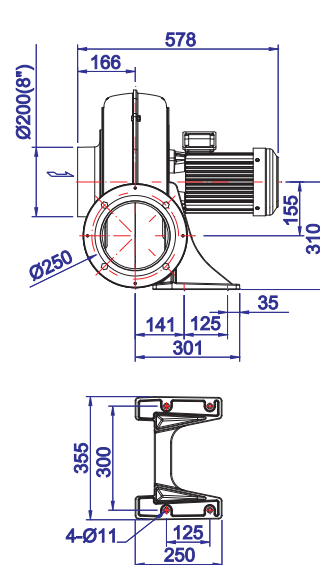

# 多翼式風機 Sirocco Fan (Centrifugal Fan)

at 50/60Hz 2Pole

型 式 Type	相 數 Phase	功 率 Output (kW)	電 壓 Voltage (V)	電 流 Current (A)	最大靜壓(吐出) Pressure (kPa)	最大風量(吐出) Air Flow (m <sup>3</sup> /min)	出口口徑 In/Out Let (mm)	噪 音 Noise Level (dB)	重 量 Weight (kg)
MS-101	3~	0.074	220 380	0.5 0.3	0.3/0.5	4.5/5.5	70x75	50/55	2.5
MS-202	3~	0.19	220 380	1.1 0.9	0.5/0.8	8/10	95x100	60/65	6
MS-405	3~	0.37	220 380	1.9 1.2	0.5/0.8	15/17	110x135	65/70	8.5
MS-751	3~	0.74	220 380	3 1.8	0.7/1	23/25	135x160	70/75	14
MS-1502	3~	1.5	220 380	5.5 3.5	0.9/1.3	29/37	145x170	75/80	20
MS-1503	3~	2.2	220 380	8 5	1.1/1.7	39/47	145x170	75/80	24
FMS200-02-F	3~	0.19	220 380	1.1 0.9	0.5/0.8	8/10	IN125/OUT100	60/65	7
FMS400-05-F	3~	0.37	220 380	1.9 1.2	0.5/0.8	15/17	IN150/OUT125	65/70	9
FMS750-1-F	3~	0.74	220 380	3 1.8	0.7/1	23/25	IN200/OUT150	70/75	15
FMS150-2	3~	1.5	220 380	5.5 3.5	0.9/1.3	29/37	IN200/OUT200	75/80	24
FMS150-3	3~	2.2	220 380	8 5	1.1/1.7	39/47	IN200/OUT200	75/80	28

## MS型性能表 Characteristic curves

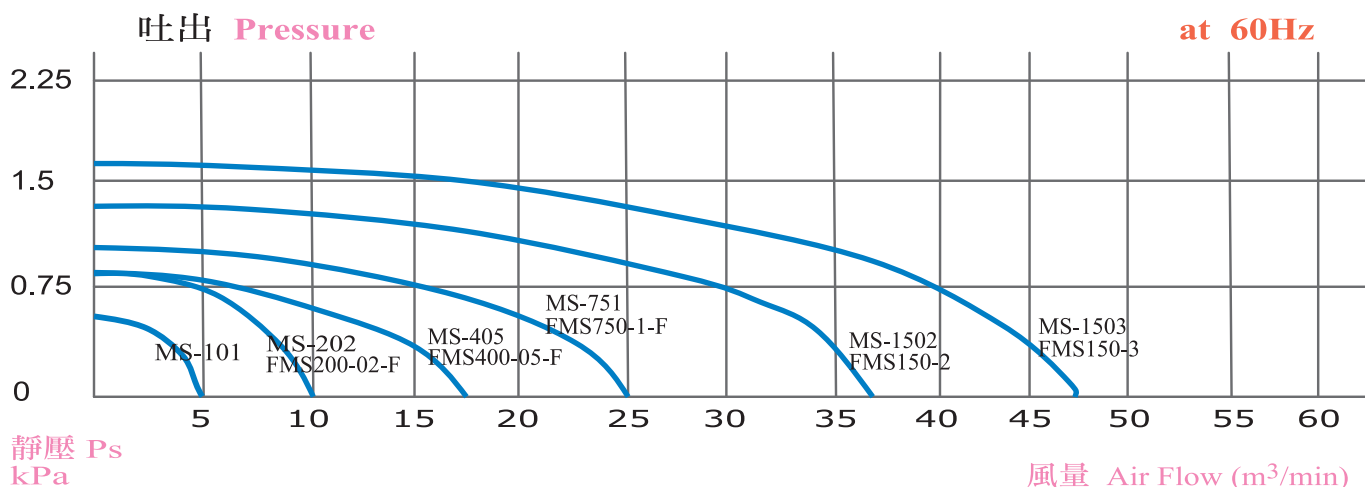
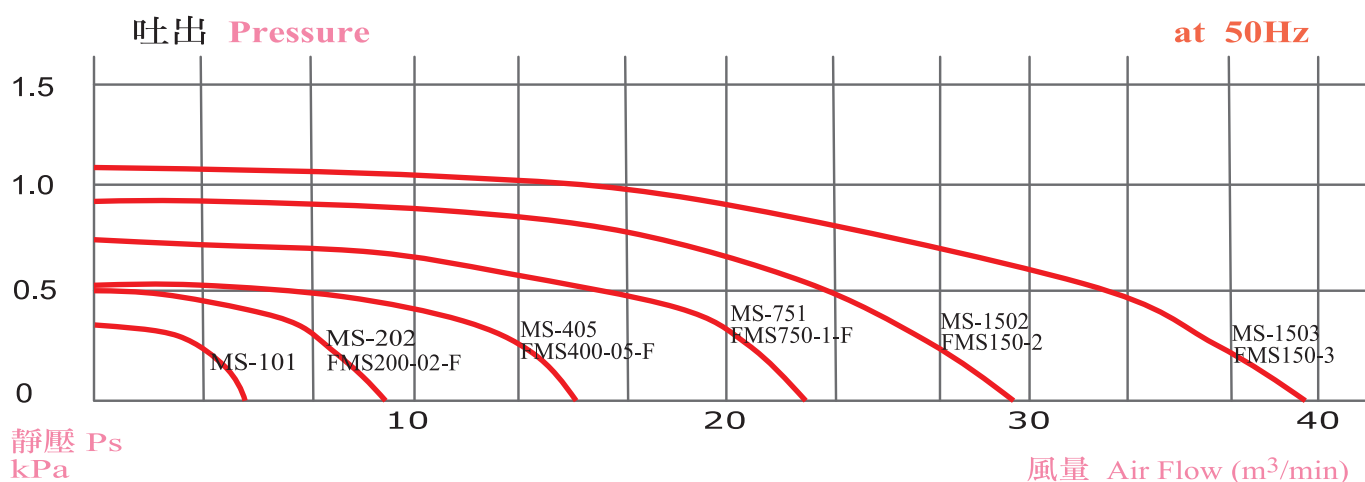

# 多翼式風機 Sirocco Fan (Centrifugal Fan)

尺寸圖 Dimension (mm)

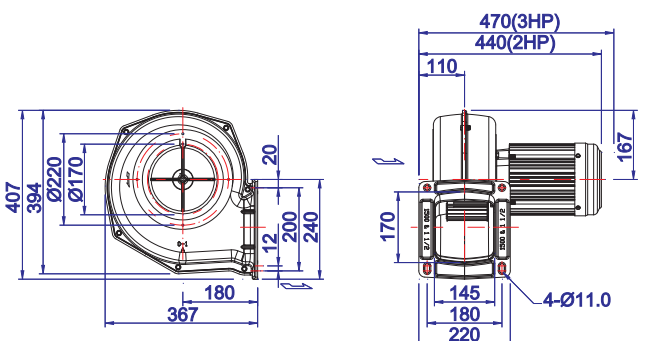
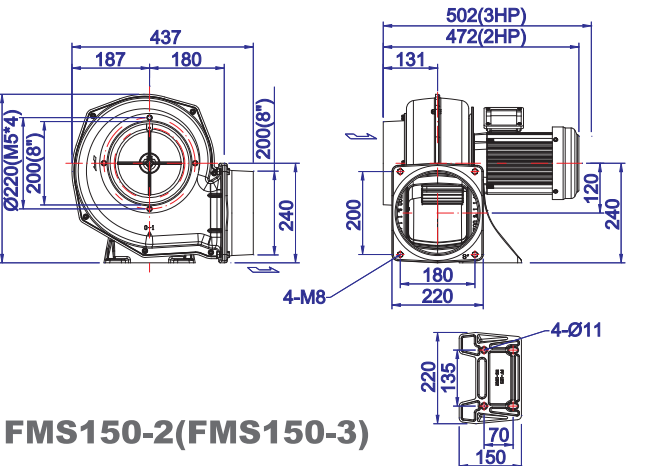
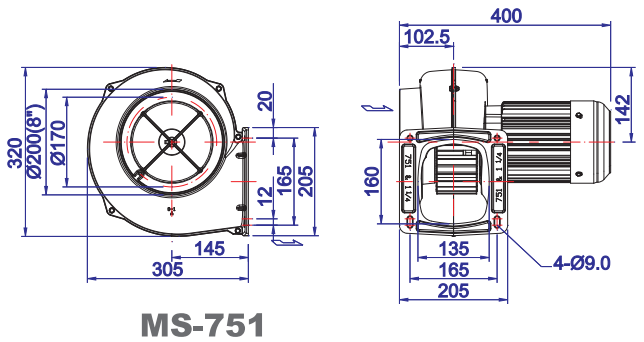
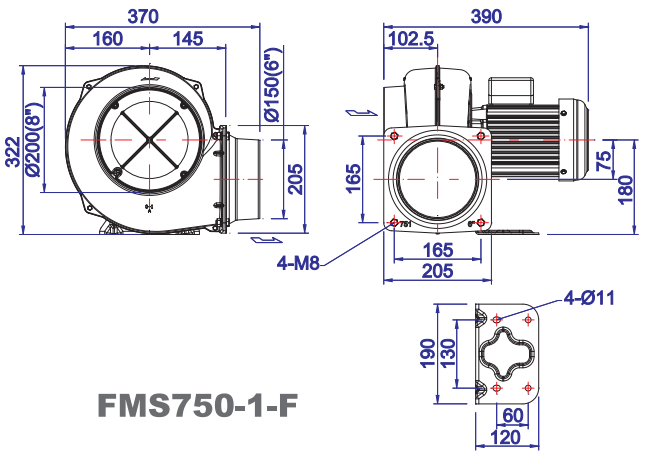
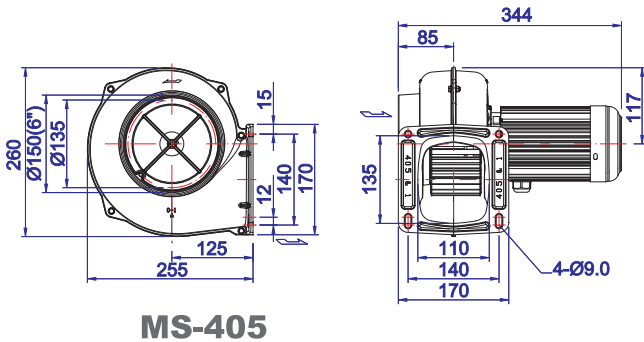
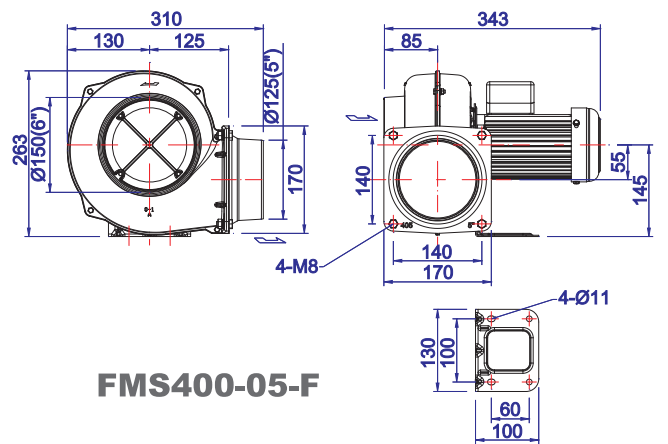
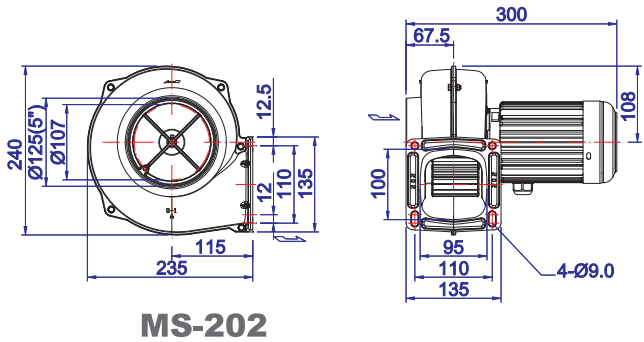
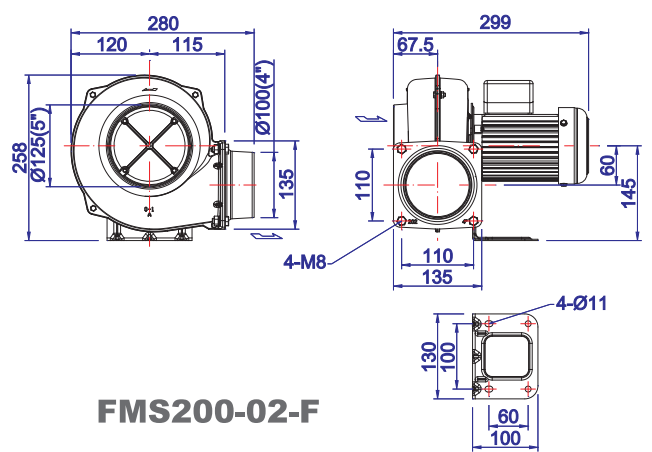
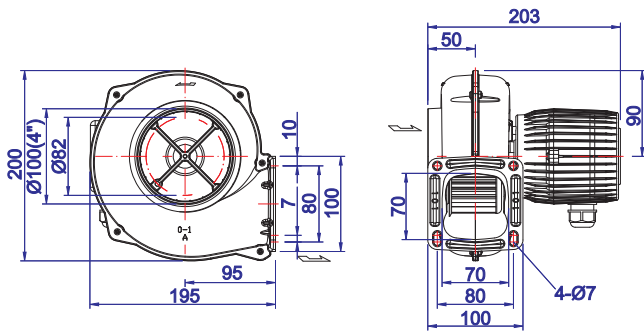

MS-1502(MS-1503)

FMS150-2(FMS150-3)

# 直翼式隔熱型風機 Heat-Resistant Radial Fan

at 50/60Hz 2Pole

型式 Type	相數 Phase	功率 Output (kW)	電壓 Voltage (V)	電流 Current (A)	最大靜壓(吐出) Pressure (kPa)	最大風量(吐出) Air Flow (m <sup>3</sup> /min)	入/出口徑 In/Out Let (mm)	噪音 Noise Level (dB)	重量 Weight (kg)	最大吸氣溫度 Suction Temperature (max)
PF75-02H	1~ 3~	0.12	220 220/380	0.8 0.7/0.45	0.5/0.7	5/6	100/75	72/75	6.5	250 °C
PF100-05NH	1~ 3~	0.37	220 220/380	2.5 1.9/1.2	0.7/1	8/10	100/100	83/88	11	
PF125-1H	1~ 3~	0.74	220 220/380	5 3/1.8	0.7/1.2	14/17	125/125	85/90	18	
PF150-2H	3~	1.5	220 380	5.5 3.5	1.3/1.9	28/33	150/150	88/92	29	
PF150-3H	3~	2.2	220 380	8 5	1.4/2.3	30/35	150/150	89/93	35	
PF200-5H-X(60HZ) PF200-5H(50HZ)	3~	3.7	220 380	13 7.5	2.6 1.8	70 60	200/200	98 90	50	

## 尺寸圖 Dimension (mm)

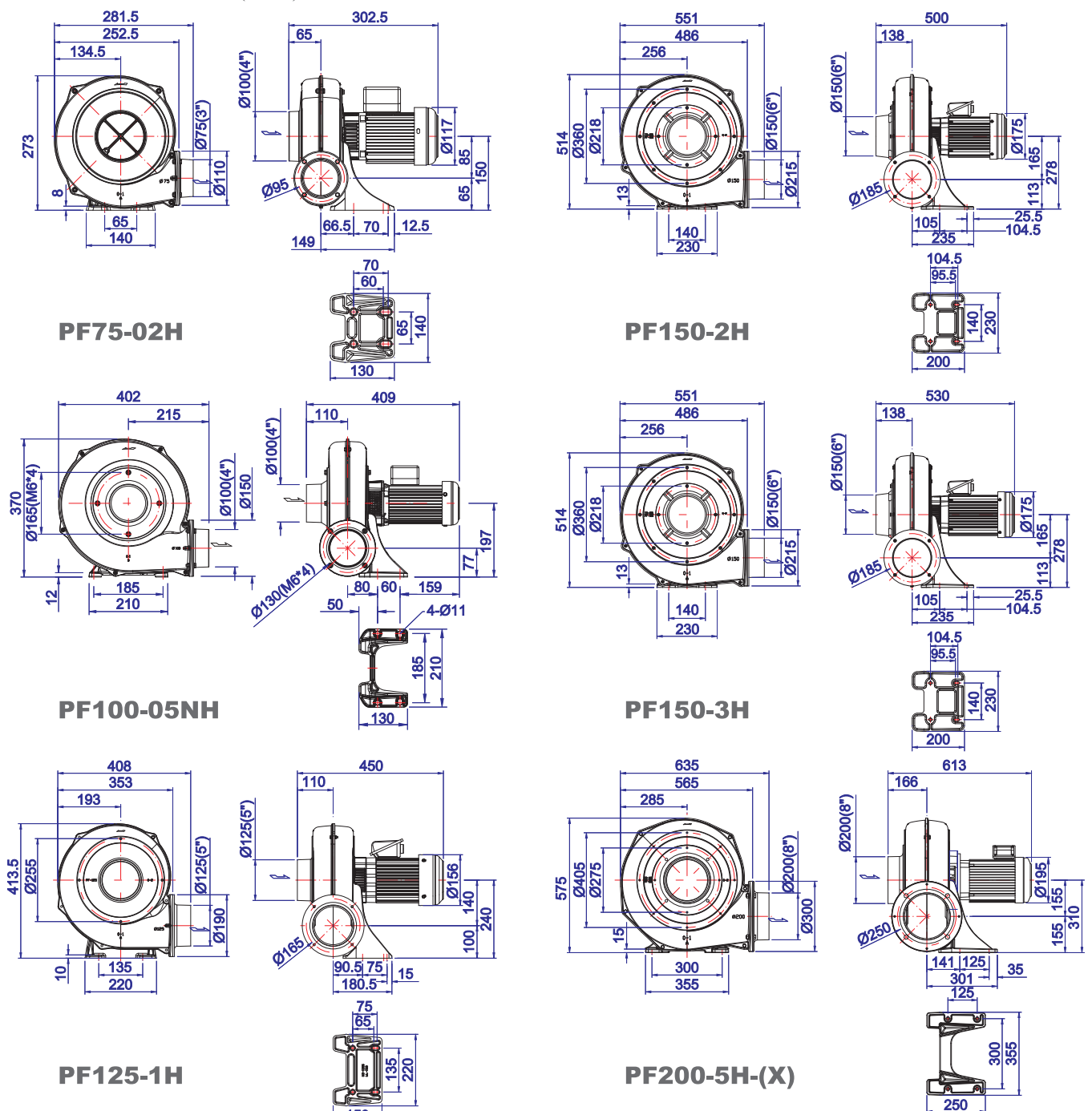

# 多翼式送風機 Sirocco Fan

用途：室內換氣、廠內通風、乾燥、冷卻、廚房排煙等。

Application: for in door and kitchen ventilation, mining ventilation, cooling, drying.



SSD-C 型

at 50/60Hz 4Pole

型式 Type	相數 Phase	頻率 Hz	輸出 功率 kW	輸入 電壓 V	滿載 電流 A	最大靜壓 (吐出) Pa	最大風量 (吐出) m <sup>3</sup> /min	噪音 dB	重量 kg	出入口 Ø mm	轉速 (min <sup>-1</sup> )
SSD-1/4C	1~ 3~	50/60	0.2	220 220/380	2 1.1/0.7	230/330	12/15	65/70	15	150/150	1400/1700
SSD-1/2C	1~ 3~	50/60	0.4	220 220/380	2.5 1.9/1.2	350/500	21/25	67/72	20	200/200	1400/1700
SSD-1C	1~ 3~	50/60	0.75	220 220/380	6 3.4/2.1	440/630	40/48	70/75	32	254/254	1400/1700
SSD-2C	3~	50/60	1.5	220/380	6.1/3.8	640/940	45/55	75/80	42	300/300	1400/1700
SSD-3C	3~	50/60	2.2	220/380	8.7/5.2	730/1000	65/76	75/80	48	300/300	1400/1700

## 多翼式風機 (馬達直結型)

尺寸圖 Dimension (mm)

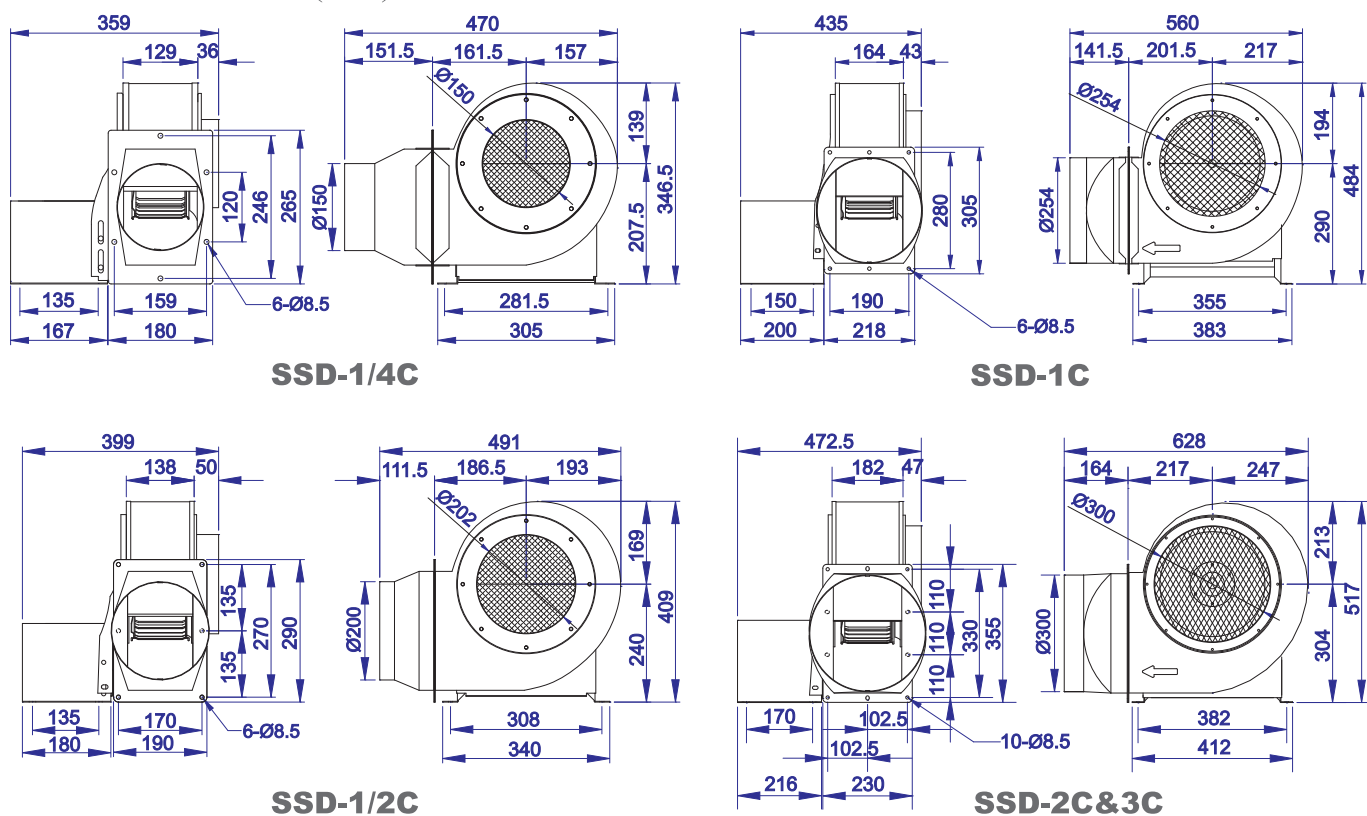

## 壓力扇 Pressure Exhaust Fan

- 小型！大風量！低噪音！
- 鐘形設計，強氣流。
- 鋼珠軸承，可長時間使用。
- 能水平、直立、傾斜安裝。
- 工廠、產業機械、辦公室隔間、洗手間、鑄造工廠、排煙罩等，皆廣用之。
- Compact, Large airflow, Low noise.
- Bell mouth design, High pressure.
- Steely bearing, suitable for continuous applications.
- Can be installed horizontally, vertically, obliquely, or in any other position.
- These ventilating fans can be used in, factories, machinery, office, toilet, foundry shop fume extraction hoods.



鐵葉  
Iron Impeller

CHV-10  
CHV-12



鑄鋁葉  
Cast aluminum  
impeller

CHV-16

at 50/60Hz

型式 Type	相數 Phase	功率 Output (W)	轉速 (min <sup>-1</sup> )	電壓 Voltage (V)	電流 Current (A)	靜壓 Pressure (Pa)	風量 Air Flow (m <sup>3</sup> /min)	噪音 Noise Level (dB)	重量 Weight (kg)
CHV-10	1~	43/50	1400/1650	110 220	1.2/1.0 0.6/0.5	40/60	18/21	45/50	5
CHV-12	1~	72/90	1400/1650	110 220	1.3/1.1 0.7/0.6	68/68	30/35	50/55	6
CHV-16	1~	160/200	1400/1650	110 220	3.4/3.0 1.7/1.5	130/130	63/73	60/65	13

# 壓力扇 (鐵葉) Pressure Exhaust Fan (metal blades)

性能曲線 Performance Date

尺寸圖 Dimension (mm)

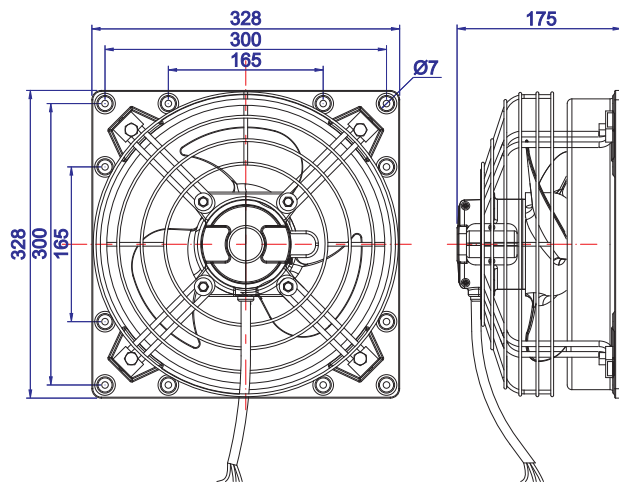
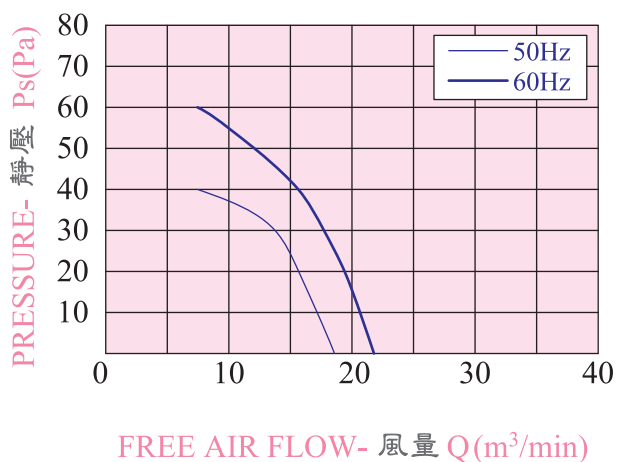

CHV-10 附邊網

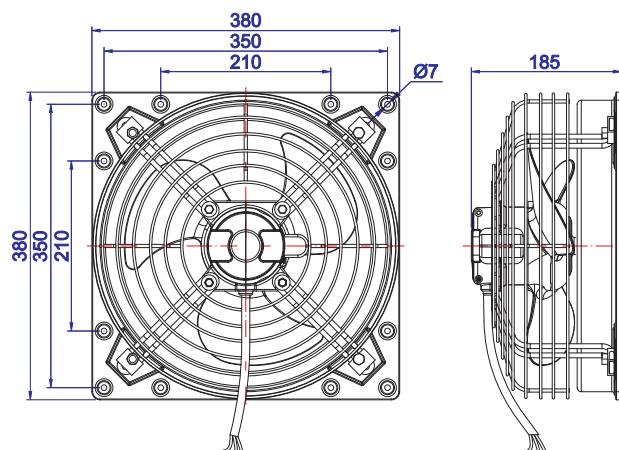
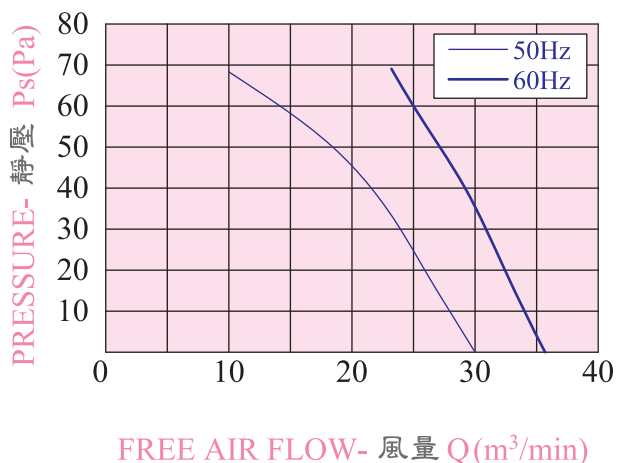

CHV-12 附邊網

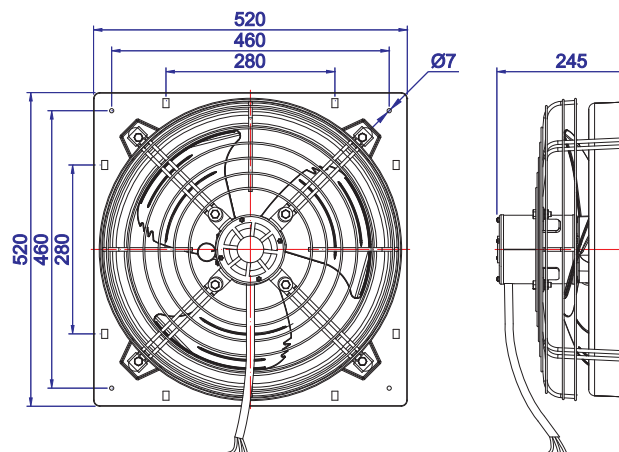
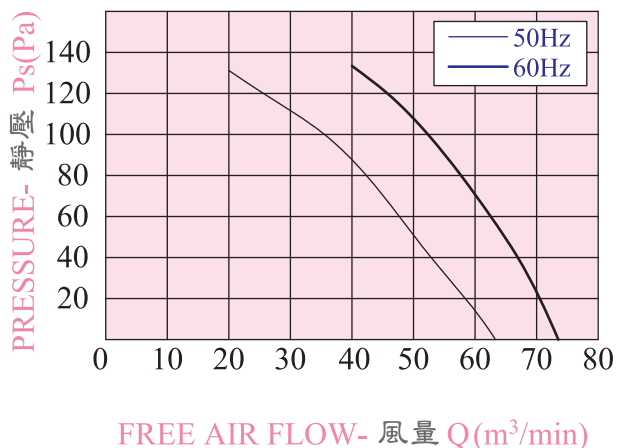

CHV-16 附邊網

# 泛用型風機 Multipurpose Fan (Centrifugal Fan)

鋁合金一體成形外殼, 堅固美觀, 減少空氣流動時產生的震動, 降低噪音。

Combine with exquisite and robust aluminum housing, it reduces the vibration and noise when the fluid travel through the blower.

螺旋氣流場設計, 降低亂流增加風機效率。

It lowers the fluids turbulence by strictly research and design.

適用於室內換氣、場內通風、乾燥、冷卻等用途。

It could be used in ventilating, drying and cooling etc.

at 50/60Hz

型 式 Type	相 數 Phase	功 率 Output (kW)	電 壓 Voltage (V)	電 流 Current (A)	最大靜壓(吐出) Pressure (Pa)	最大風量(吐出) Air Flow (m <sup>3</sup> /min)	轉速 Rotating speed (min <sup>-1</sup> )	噪 音 Noise Level (dB)	重 量 Weight (kg)
SFD150-02	1~ 3~	0.19	110/220 220/380	2.8/1.4 1.1/0.9	230/330	16/20	1400/1700	65/70	11
SFD200-05AL	1~ 3~	0.37	110/220 220/380	5/2.5 1.8/1.2	500/700	17/27	1400/1700	73/77	14
TFD200-1	1~ 3~	0.74	1~220 220/380	5 3/1.8	500/850	25/30	2850/3450	84/88	18

## 性能表 Characteristic Curves

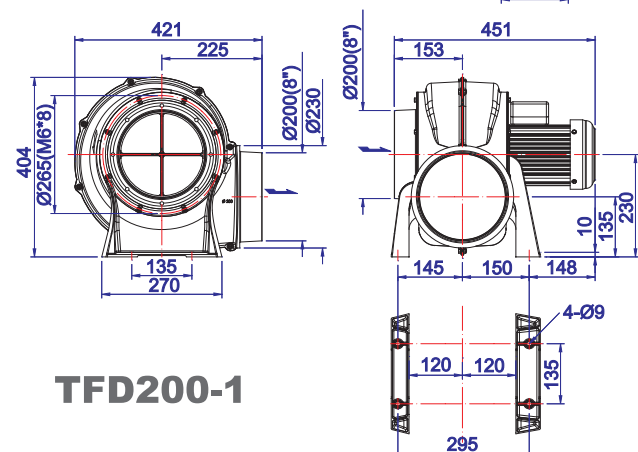
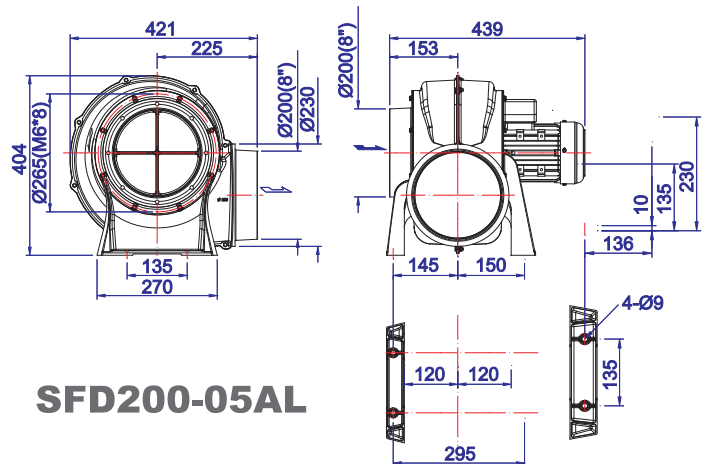
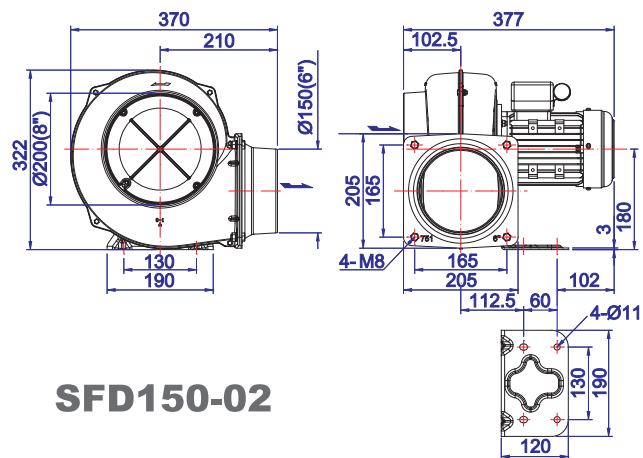
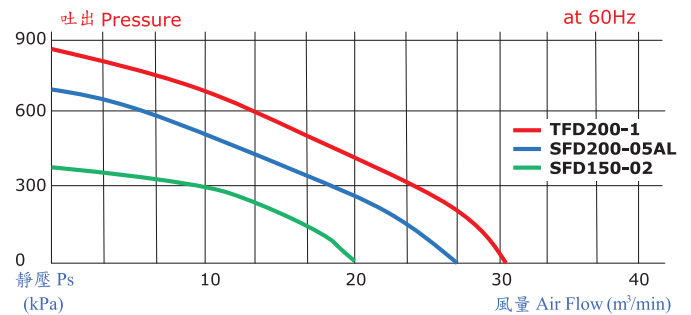
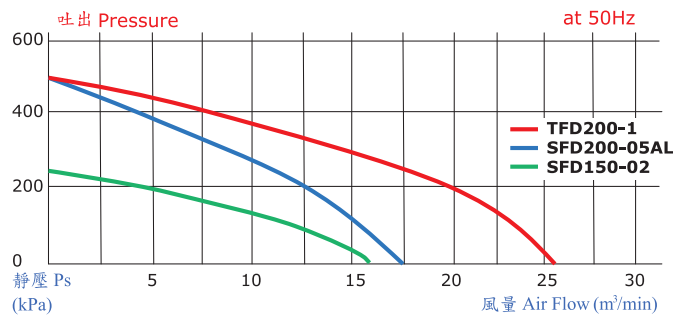

## 相關產品 *Correlated Product*



**RB 環形鼓風機系列**



**CX 透浦式系列**



**TB 透浦式系列**

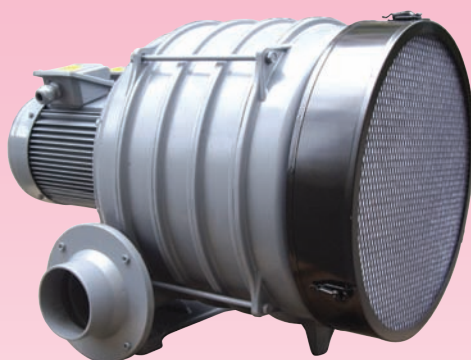

**HTB 透浦多段式系列**



**旋風式工業集塵機**



**水滴型風刀**



中國能效

GB18613-2020

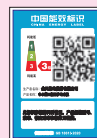

GB19761-2009



UL/CAN



IE3 Motor



CE



批發・製造・買賣 manufacturer, distributor



CHUAN FAN

全風機電股份有限公司  
全風風機股份有限公司  
CHUAN-FAN ELECTRIC CO., LTD.

營運部/楊梅廠：  
桃園市楊梅區(幼獅工業區)青年路6-2號(幼獅交流道南下旁)  
No.6-2 Qingnian Rd, Youth Industrial Park, Yangmei Dist,  
Taoyuan City 32661, Taiwan

Tel:886-3-4643788 Fax:886-3-4643771

銅鑼廠：苗栗縣銅鑼鄉銅鑼工業區自強路23號  
Tel:037-980-722 Fax:037-980-725



台北門市：新北市三重區先復路一段28號

Tel:02-2995-3386 Fax:02-2995-2295

高雄門市：高雄市九如一路214巷11號(九如交流道北上旁)

Tel:07-380-9512 Fax:07-380-9677

<http://www.chuanfan.com>

<http://www.chuanfan.com.tw>

e-mail:service@chuanfan.com

全風  
Chuan-Fan